

WIRE ROPE ISOLATORS: 'HELICAL'

DEFINITION
series CB1270

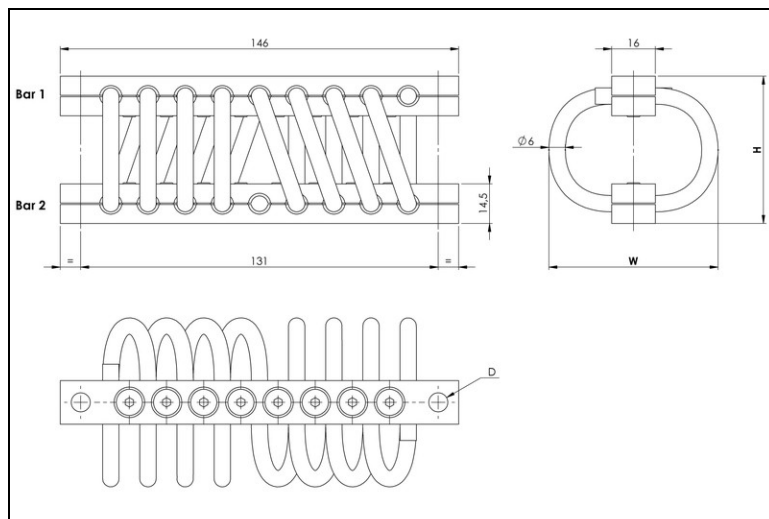

- All metal multidirectional anti-vibration/shock mounts
- Exceptional reliability and long life
- High damping
- No aging
- Corrosion resistant
- Unequalled temperature range : -180°C to +300°C / -290F to 570 F
- Great adaptability/versatility

Specials on request

(material size and number of loops, etc.)

Dimensions are in millimeters. For reference only

SERIES
Materials and finishes (meets RoHS requirements)
CB1270
Cable: stainless steel galvanized available: CBG
Retainer bars: aluminium alloy/ SurTec
Screws: alloy steel/ zinc plate
Inserts: stainless steel
All stainless steel : CBSS
Other materials on request

MODEL			
	height H (mm)	width W (mm)	weight (kg)
-10	48	55	0,33
-20	54	62	0,36
-25	59	70	0,38
-30	63	79	0,41
-35	63	88	0,42
-38	67	94	0,44
-40	67	99	0,45
-50	82	107	0,49
-60	98	128	0,56

INTERFACES			
fixtures holes D	Bar 1		
	2 through holes Ø7mm	2 through holes Ø7mm counter-sunk 90°	2 inserts M6
Bar 2			
2 through holes Ø7mm	no suffix	not standard	not standard
2 through holes Ø7mm counter-sunk 90°	CM	CM2	not standard
2 inserts M6	IM	CIM	IM2

C B 1 2 7 0 - 1 0 C I M

SERIE: CB1270

'Helical' mount from the CB1270 series

MODEL: -10

height: 48mm

width: 55mm

weight: 0,33kg

loops: serie

standard is 08 loops

INTERFACE: CIM

2 through holes Ø7mm

counter-sunk 90° in bar 1,

2 inserts M6 in bar 2

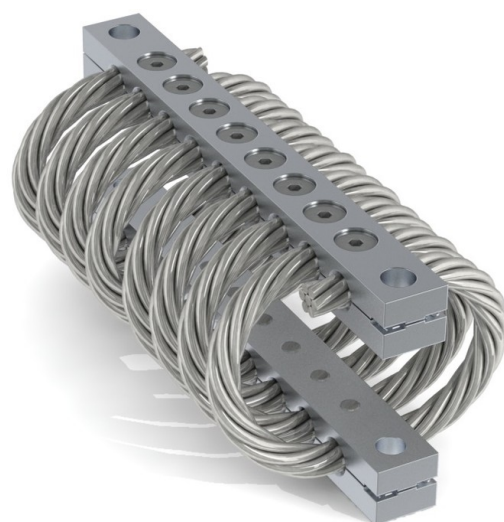

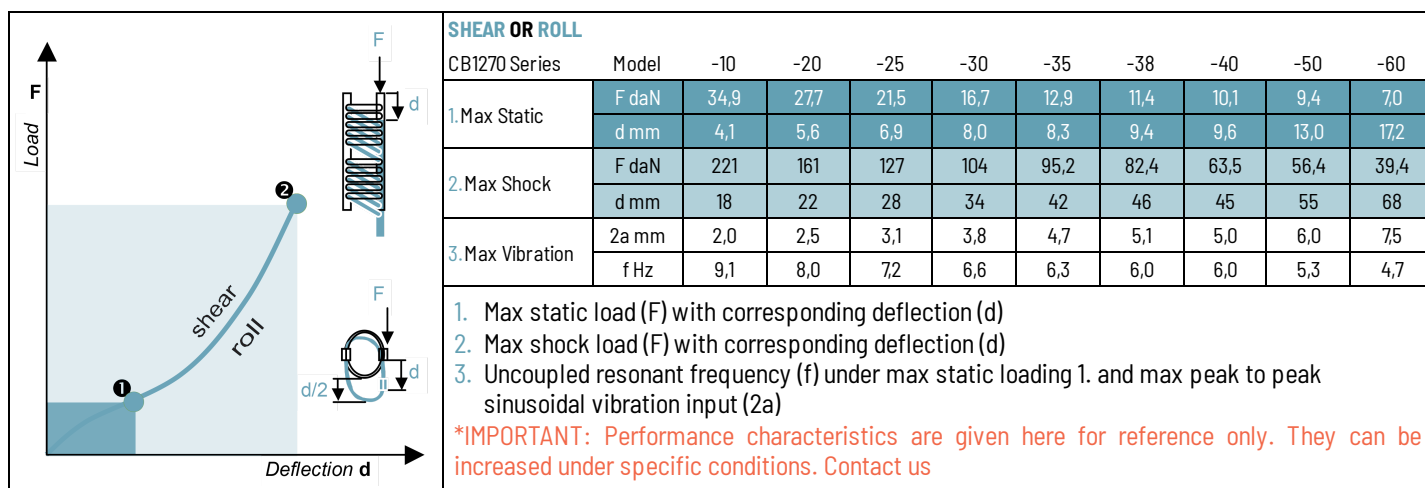
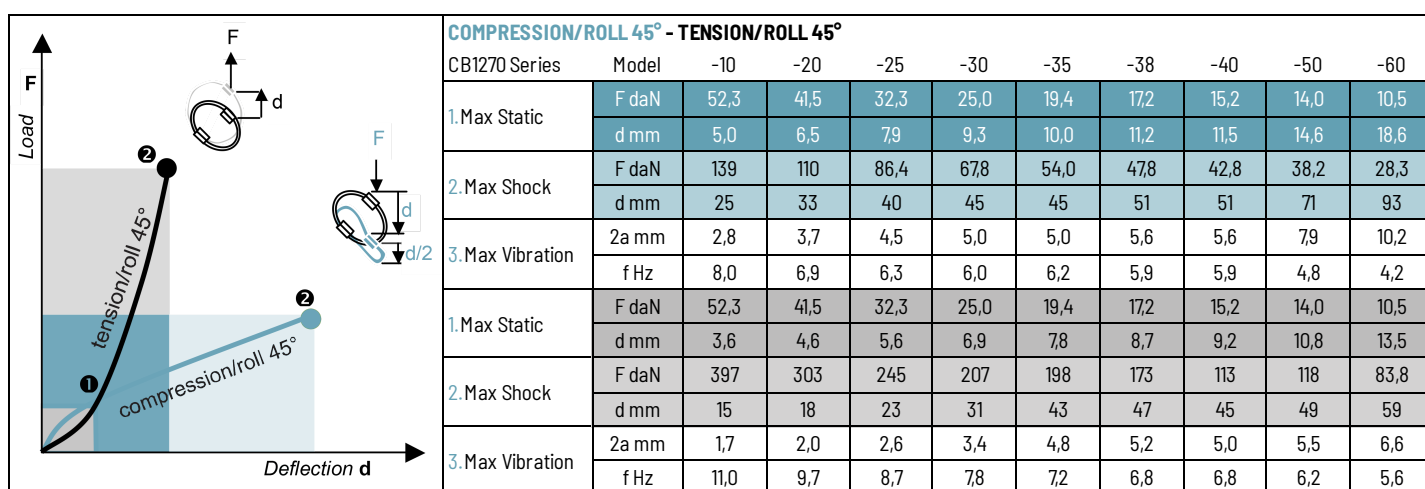
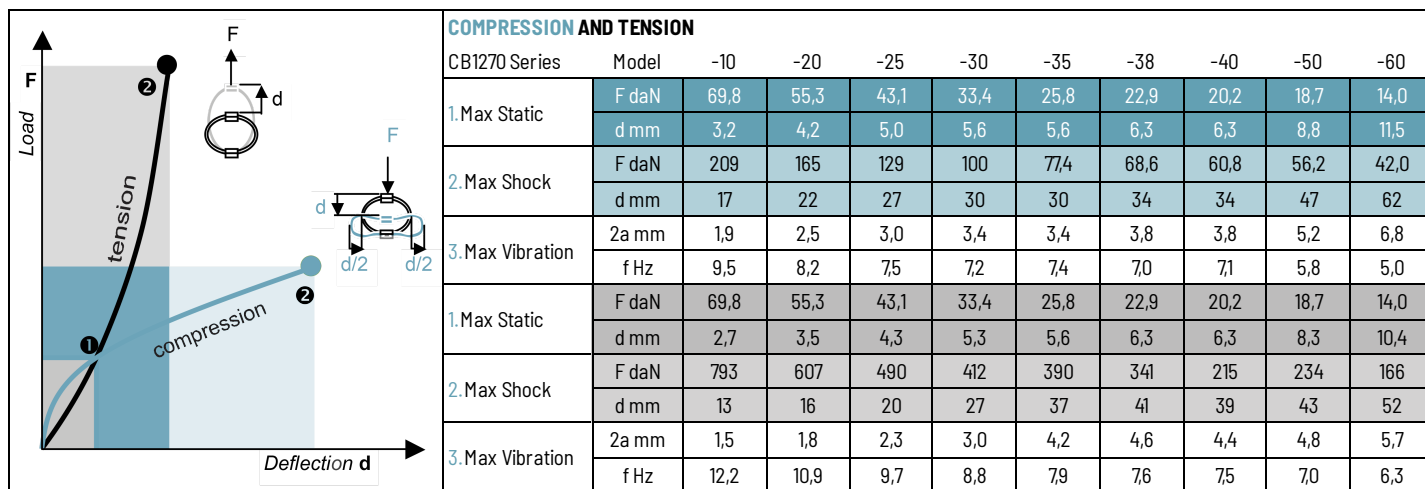

TYPICAL SHOCK/VIBRATION SPECIFICATIONS:

- Air** AIR 7306, MIL-E-5400, MIL-C-172, MIL-STD-810
- Ground Forces** GAM EG13A, SEFT 001, MIL-STD-810, VG 9533
- Marine** GAM EG13C, IT25-21/96-31/15-86, MIL-S-167, MIL-S-901, STANAG 042, BV 043.73, BV 044
- Others** GAM EMB1, GAM EMBT4, DEF STAN 07-55, IEC 571, FINABEL 2C